

Power Distribution Box DB-9 (Blackmagic PYXIS, V-Mount)

M49-DB9-V

Install Camera Mount Bracket onto rear two 1/4-20s, using 4mm or 5/32 allen.

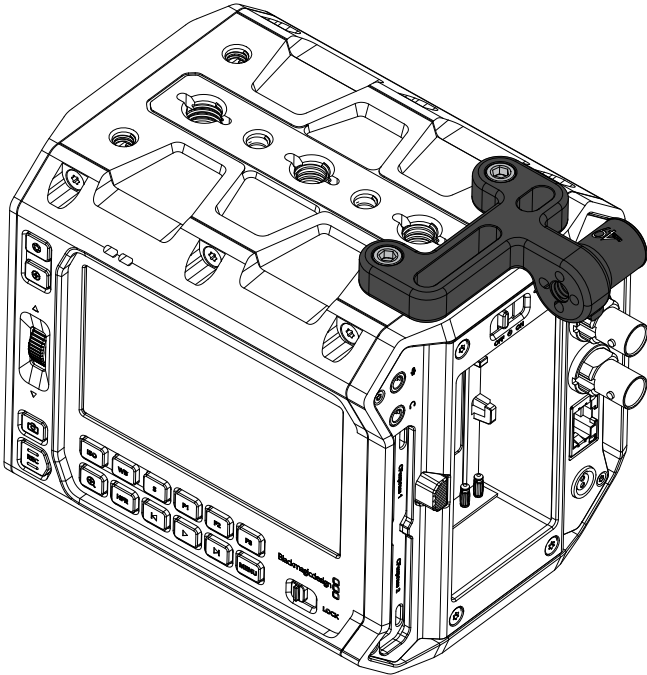

For Remote Start / Stop function (R/S), install USB-C Cable into DB-9 REMOTE port.

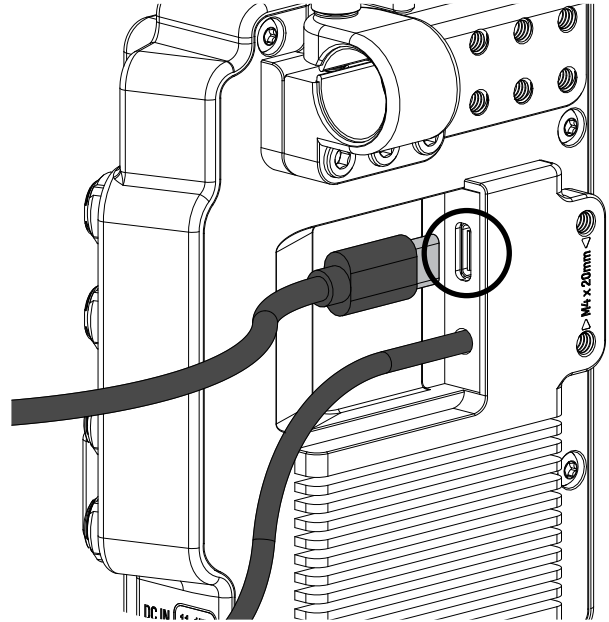

Attach to camera using 15mm clamp and tighten friction thumbscrew.

When using wide batteries, adjust battery plate position to expose power outputs.

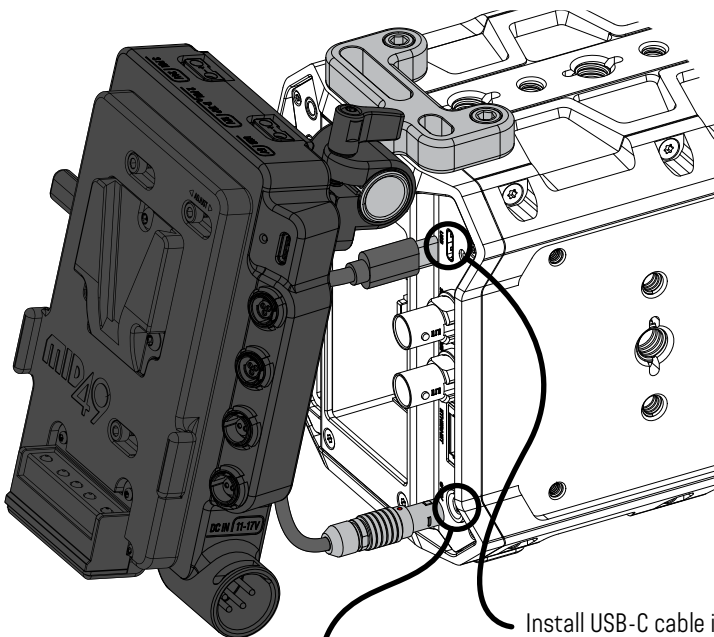

Install USB-C cable into camera USB port.

Install 2-pin connector into camera DC IN port.

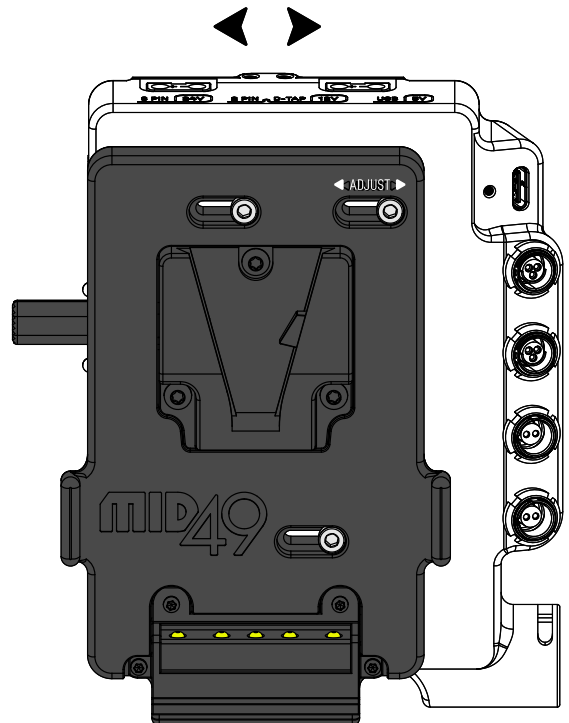

Operating Voltage

Source

On-board batteries (BATT)

DC input (DC-IN)

Voltage Range

12.5 - 17V

11-17V (Note that Blackmagic PYXIS may shut down below 11.8V)

Power Source Selection

When two valid sources are present (BATT and DC-IN), the DC input will be selected when the voltage is above 12V. When the measured DC input voltage under load is below 12V, and an on-board battery (BATT) is present, DB-9 will switch to BATT.

* Due to the nature of block battery performance, the DC input voltage must be above 14V at initial insertion to be valid.

LED Indicators

On the side of the DB-9, LEDs corresponding to the active sources are illuminated. When a source is valid and active, the LED will glow GREEN. When a source is invalid, either above 17V or below thresholds described above, the LED will glow RED.

Displayed Voltage

The PYXIS 2-pin DC input does not accept battery data so, when using DB-9, the camera will measure and display the active source voltage.

Battery Capability

For DB-9 to intelligently monitor camera and accessory power and prevent a brownout, the slide switch setting must match or be lower than the maximum sustained current rating of the power source. This information is commonly found on the battery or power supply's label or the manufacturer's website and is often listed as 10A, 12A, 20A, or similar.

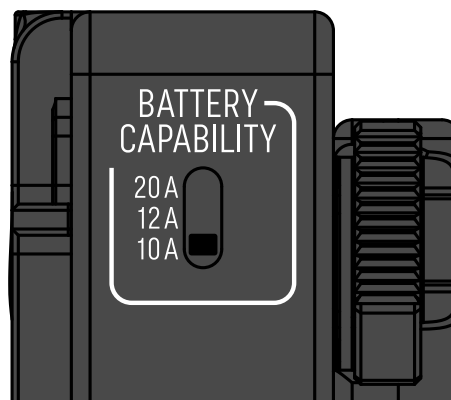

Power Outputs

Type

D-Tap

2-pin LEMO Compatible

3-pin Fischer Compatible

USB-C PD

Voltage

Source Voltage (11-17V)

Source Voltage (11-17V)

Regulated 24V at 2.5A

Regulated 5V at 3A

Smart Fuse

Rather than a traditional fuse, DB-9 monitors the current going to the camera and calculates the remaining current budget for accessories. For example, the PYXIS uses approximately 1.5A, so with BATTERY CAPABILITY set to 10A, the remaining 8.5A would be allocated to accessories. If that 8.5A accessory limit is exceeded, DB-9 will cut accessory power, leaving the camera running. Once the accessories drawing excess current have been removed, the RESET button can be pressed to re-enable accessory power.

Example Calculation with a 12V Battery

Battery Capability	10.0A
Blackmagic PYXIS	- 1.5A
Video Transmitter	- 1.5A
Wireless FIZ	- 3.0A (24V at 1.5A)
Remaining Power Budget	4.0A

Remote Start / Stop

When the USB-C Cable is installed into the PYXIS USB-C Port, ARRI standard run / stop function is present on 3-pin Fischer connectors.

Swapping Battery Plates

To change from a V-Mount battery plate to a Gold Mount battery plate, remove (3) M3x10mm socket cap screws using a 2.5mm allen wrench and disconnect power and data connections. Reverse process for installation. Be careful not to pinch wires during assembly or damage may result.

Tilta Warning

When using a Tilta Nucleus lens control system, only one 3-pin Fischer cable is required. **Do not use an additional power cable.** Due to Tilta's design error, the Nucleus will short circuit 24V and 12V causing accessories to lose power. If this happens, remove the second cable and push the DB-9 reset button.